

PRECISION TOOL VISES / QGG 系列精密工具平口钳

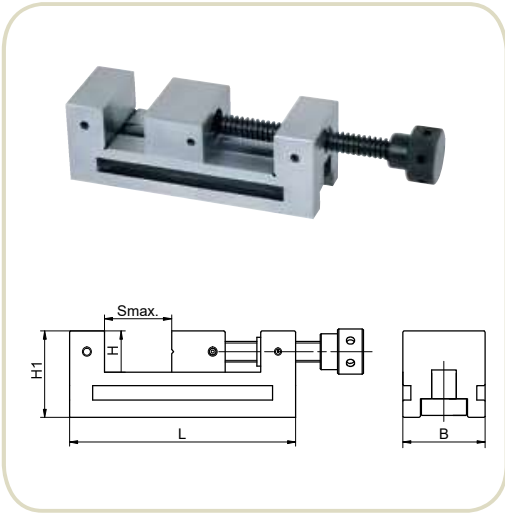

Order No. 货号	Size 型号	B mm	H mm	H ₁ mm	Smax mm	L mm	重量 Wt(Kg)
QGG50	QGG50	50	25	50	65	155	3.0
OGG60	OGG60	60	25	50	55	110	2.4
OGG63	OGG63	63	32	65	85	190	3.8
OGG73	OGG73	73	35	74	100	210	5.0
OGG80	OGG80	80	40	84	100	220	6.5
OGG88	OGG88	88	40	88	125	250	11.0
OGG100	OGG100	100	45	95	125	260	13.0
OGG125	OGG125	125	50	110	160	300	19.5
QGG125A	QGG125A	125	50	110	210	350	23.0
QGG150	QGG150	150	50	110	175	315	23.8

PRECISION TOOL VISES / QGG-C 系列精密工具平口钳

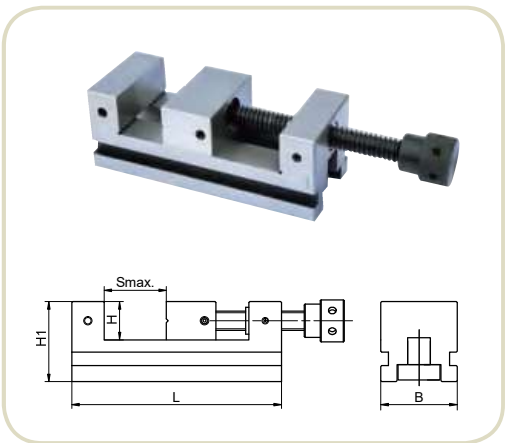

Order No. 货号	Size 型号	B mm	H mm	H ₁ mm	Smax mm	L mm	重量 Wt(Kg)
OGG50-C	OGG50-C	50	25	50	65	155	3.0
OGG60-C	OGG60-C	60	25	50	55	110	2.4
QGG63-C	QGG63-C	63	32	65	85	190	3.8
QGG73-C	QGG73-C	73	35	74	100	210	5.0
QGG80-C	QGG80-C	80	40	84	100	220	6.5
OGG88-C	OGG88-C	88	40	88	125	250	11.0
QGG100-C	QGG100-C	100	45	95	125	260	13.0
OGG125-C	OGG125-C	125	50	110	160	300	19.5
QGG125A-C	QGG125A-C	125	50	110	210	350	23.0
QGG150-C	QGG150-C	150	50	110	175	315	23.8

PRECISION TOOL VISES / 28600 型高精精密工具平口钳

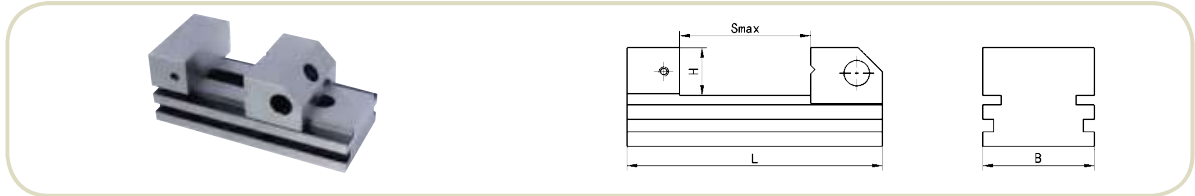

货号 Order No.	型号 Model	钳口宽 B Jaw Width (mm)	钳口深 H Jaw Depth (mm)	开口度 S Max. Opening (mm)	总长 L Over Length (mm)
28600 110	28600 110	34	15	25	75
28600 120	28600 120	45	20	50	110
28600 130	28600 130	70	30	80	160
28600 140	28600 140	90	40	120	210
28600 150	28600 150	120	40	150	280

PRECISION SINE TOOL VISE / ZXQGG 系列精密正弦工具平口钳

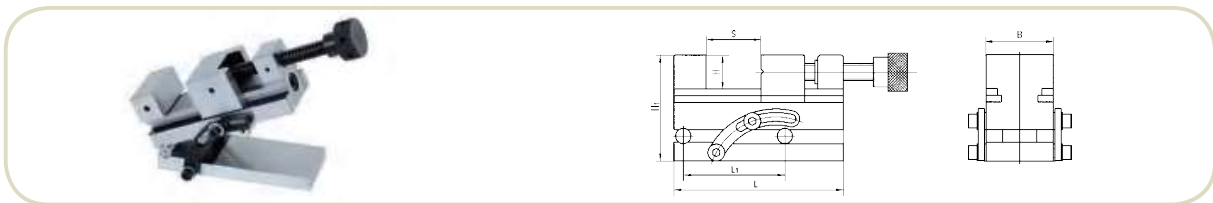

货号 Order No.	型号 Model	B mm	H mm	H _i mm	S _{max} mm	L mm	L1		调整角度范围 Adjustable angle range
							mm	in	
ZXQGG50	ZXQGG50	50	25	86.6	60	140	100	4	0~45°
ZXQGG63	ZXQGG63	63	32	94.6	85	175		5	
ZXQGG73	ZXQGG73	73	35	111	90	190		5	
ZXQGG80	ZXQGG80	80	40	121	95	200		5	
ZXQGG88	ZXQGG88	88	40	125	120	235		5	
ZXQGG100	ZXQGG100	100	45	139.2	125	245		5	
ZXQGG125	ZXQGG125	125	50	154.2	160	285		200	
ZXQGG150	ZXQGG150	150	50	160.9	190	330	200	10	

PRECISION SINE TOOL VISE / ZXQKG 系列精密正弦工具平口钳

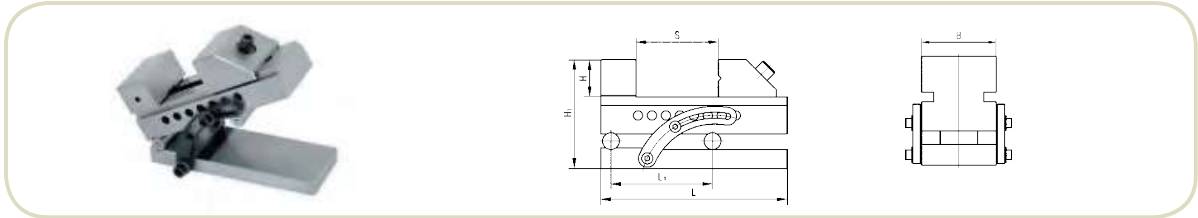

货号 Order No.	型号 Model	B mm	H mm	H ₁ mm	S _{max} mm	L mm	L1		调整角度范围 Adjustable angle range
							mm	in	
ZXQKG50	ZXQKG50	50	25	79.36	65	140	100	4	0~45°
ZXQKG63	ZXQKG63	63	32	92.36	85	175		5	
ZXQKG73	ZXQKG73	73	35	104	100	190		5	
ZXQKG80	ZXQKG80	80	40	117	100	200		5	
ZXQKG88	ZXQKG88	88	40	122	125	235		5	
ZXQKG100	ZXQKG100	100	45	134.08	125	245		200	
ZXQKG125	ZXQKG125	125	50	144.08	160	285	200	10	
ZXQKG150	ZXQKG150	150	50	150.9	200	330	200	10	

PRECISION UNIVERSAL VISE / CHM 型万向角度回转平口钳

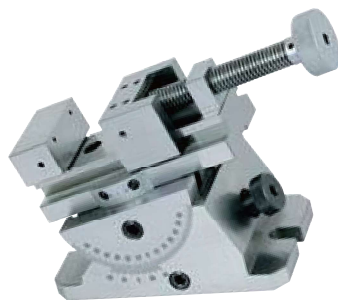

货号 Order No.	型号 Model	钳口宽 Jaw width (mm)	钳口深 JawsDepth (mm)	开口度 Max.Opening(mm)	外形尺寸 Outside Size (mm)
CHM50	CHM50	50	25	70	180x72x112
CHM80	CHM80	70	30	80	195x110x137
CHM120	CHM120	120	40	155	400x180x21

PRECISION MODULAR VISES / 精密组合平口钳

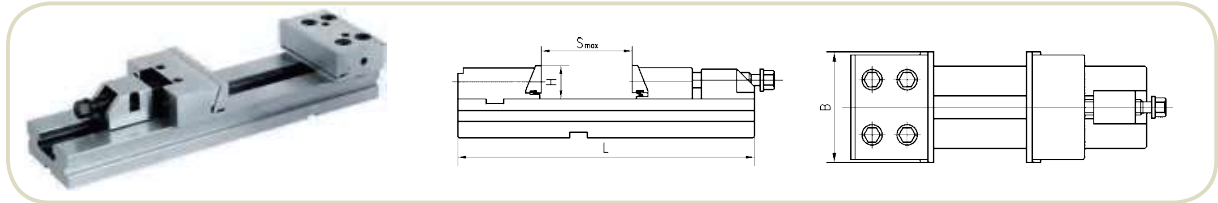

货号 Order No.	型号 Model	B mm	H mm	Smax mm	L mm	最大夹紧力(Kg) Clamping force
GT100- I	GT100- I	100	30	100	270	3000
GT125- I	GT125- I	125	40	150	345	3000
GT150A- I	GT150A- I	150	50	200	420	5000
GT150B- I	GT150B- I	150	50	300	520	5000
GT150C- I	GT150C- I	150	50	400	620	5000
GT175A- I	GT175A- I	175	60	200	455	6000
GT175B- I	GT175B- I	175	60	300	555	6000
GT175C- I	GT175C- I	175	60	400	655	6000
GT175D- I	GT175D- I	175	60	500	755	6000
GT175E- I	GT175E- I	175	60	600	855	6000
GT200A- I	GT200A- I	200	65	200	495	10000
GT200B- I	GT200B- I	200	65	300	595	10000
GT200C- I	GT200C- I	200	65	400	695	10000
GT200D- I	GT200D- I	200	65	500	795	10000
GT200E- I	GT200E- I	200	65	600	895	10000
GT300A- I	GT300A- I	300	80	200	535	12000
GT300B- I	GT300B- I	300	80	300	635	12000
GT300C- I	GT300C- I	300	80	400	735	12000
GT300D- I	GT300D- I	300	80	500	835	12000
GT300E- I	GT300E- I	300	80	600	935	12000
GT300F- I	GT300F- I	300	80	700	1035	12000
GT300G- I	GT300G- I	300	80	800	1135	12000



PRECISION MODULAR VISES WITH SWIVEL BASE / 带底座精密组合平口钳

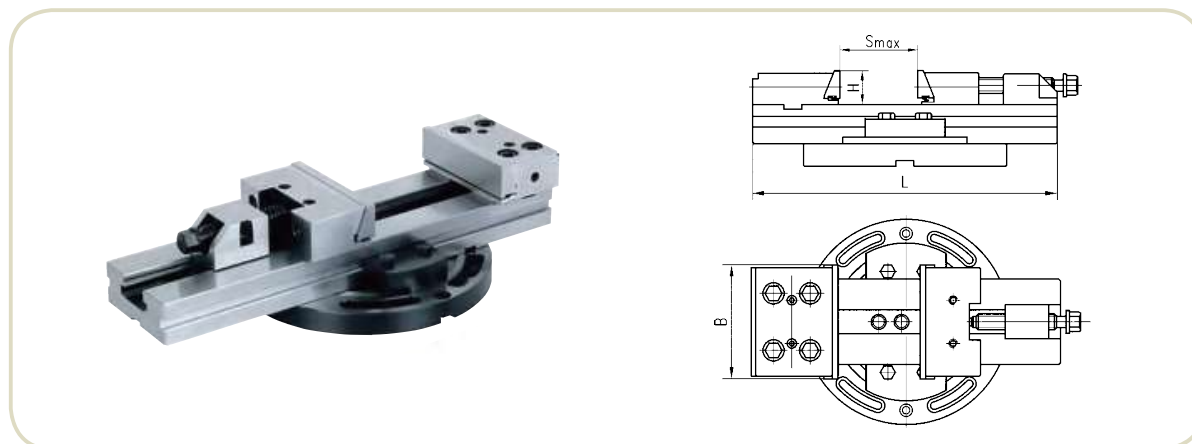

货号 Order No.	型号 Model	B mm	H mm	Smax mm	L mm	最大夹紧力(Kg) Clamping force
GT100- II	GT100- II	100	30	100	270	3000
GT125- II	GT125- II	125	40	150	345	3000
GT150A- II	GT150A- II	150	50	200	420	5000
GT150B- II	GT150B- II	150	50	300	520	5000
GT150C- II	GT150C- II	150	50	400	620	5000
GT175A- II	GT175A- II	175	60	200	455	6000
GT175B- II	GT175B- II	175	60	300	555	6000
GT175C- II	GT175C- II	175	60	400	655	6000
GT175D- II	GT175D- II	175	60	500	755	6000
GT175E- II	GT175E- II	175	60	600	855	6000
GT200A- II	GT200A- II	200	65	200	495	10000
GT200B- II	GT200B- II	200	65	300	595	10000
GT200C- II	GT200C- II	200	65	400	695	10000
GT200D- II	GT200D- II	200	65	500	795	10000
GT200E- II	GT200E- II	200	65	600	895	10000
GT300A- II	GT300A- II	300	80	200	535	12000
GT300B- II	GT300B- II	300	80	300	635	12000
GT300C- II	GT300C- II	300	80	400	735	12000
GT300D- II	GT300D- II	300	80	500	835	12000
GT300E- II	GT300E- II	300	80	600	935	12000
GT300F- II	GT300F- II	300	80	700	1035	12000
GT300G- II	GT300G- II	300	80	800	1135	12000

QUICK ACTION PRECISION MODULAR VISES / 快动式精密组合平口钳



货号 Order No.	型号 Model	B mm	H mm	Smax mm	L mm	最大夹紧力(Kg) Clamping force
GT125-III	GT125-III	125	40	150	345	3000
GT150A-III	GT150A-III	150	50	200	420	5000
GT150B-III	GT150B-III	150	50	300	520	5000
GT175C-III	GT175C-III	175	60	400	655	6000

 QUICK ACTION PRECISION MODULAR VISES WITH SWIVEL BASE
 / 带底座快动式精密组合平口钳

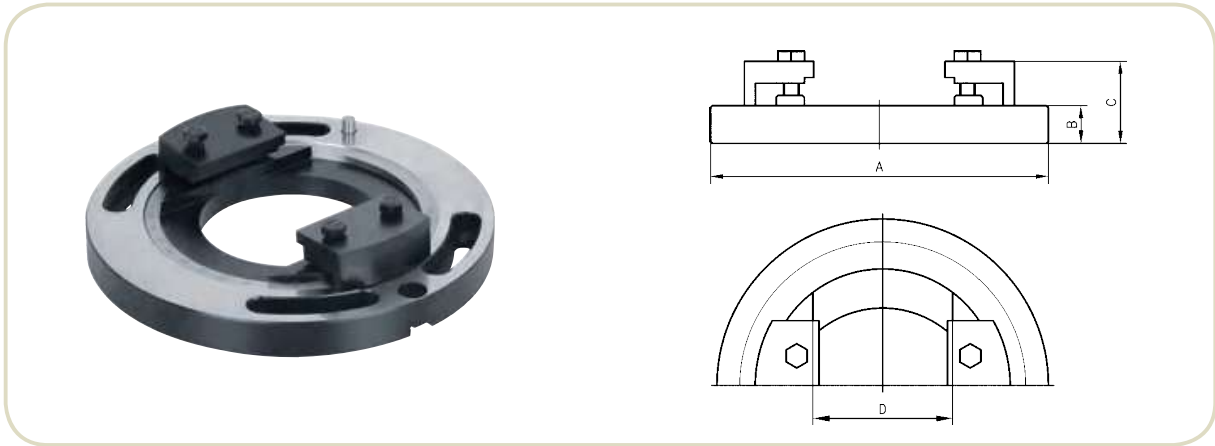

货号 Order No.	型号 Model	B mm	H mm	Smax mm	L mm	最大夹紧力(Kg) Clamping force
GT125-IV	GT125-IV	125	40	150	345	3000
GT150A-IV	GT150A-IV	150	50	200	420	5000
GT150B-IV	GT150B-IV	150	50	300	520	5000
GT175C-IV	GT175C-IV	175	60	400	655	6000

SWIVEL BASE SERIES / 平口钳圆底座

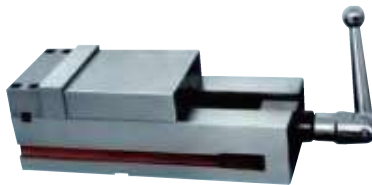

货号 Order No.	型号 Model	A mm	B mm	C mm	D mm	使用范围 Suitable Vises
GT100-08	GT100-08	180	20	43.5	75	GT100-I
GT125-08	GT125-08	226	23	47	95	GT125-I GT125-III
GT150-08	GT150-08	290	28	58	125	GT150A(B,C)-I GT150A(B)-III
GT175-08	GT175-08	320	28	58	145	GT175A(B,C,D,E)-I GT175C-III
GT200-08	GT200-08	370	34	74	170	GT200A(B,C,D,E)-I
GT300-08	GT300-08	400	38	78	195	GT300A(B,C,D,E,F,G)-I

QM16N SERIES MACHINE VICE / QM16N型精密机用平口钳



货号 Order No.	型号 Model	钳口宽度 Width of Jaw (mm)	钳口高度 Height of Jaw (mm)	钳口开口度 Max. Opening(mm)	总长度 Over length (mm)
QM1680N	QM1680N	80	24	75	256
QM16100N	QM16100N	100	32	100	305
QM16160N	QM16160N	160	45	140	438
QM16200N	QM16200N	200	50	190	517
QM16250N	QM16250N	250	70	250	656

ACCU-LOCK PRECISION MACHINE VISES / QM 型精密机用平口钳

货号 Order No.	型号 Model	钳口宽度 Width of Jaw mm	钳口高度 Height of Jaw mm	钳口开口度 Max. Opening mm	毛重/净重 GW./NW. kg	装箱数量 Q' TY	包装尺寸(mm) Packing Size
QM16100	QM16100	100	32	100	17/16	1	380x250x180
QM16125	QM16125	125	40	125	21/20	1	460x290x190
QM16160	QM16160	160	45	150	36/35	1	480x320x220
QM16200	QM16200	200	50	190	58/56	1	580x360x260

Q93 DOUBLE-ACTION ANGLE TIGHT MACHINE VICE

/ Q93 型双向角度压紧系列平口钳

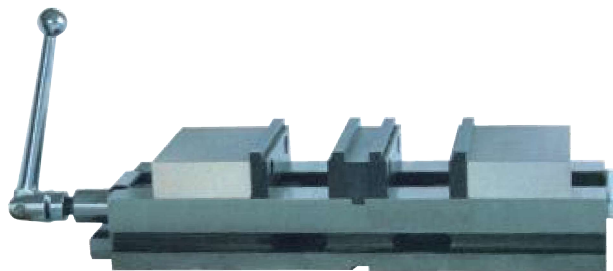

货号 Order No.	型号 Model	钳口宽度 Width of Jaw mm	钳口高度 Height of Jaw mm	钳口开口度 Max. Opening mm	毛重/净重 GW./NW. kg	装箱数量 Q' TY	包装尺寸(cm) Packing Size
Q93100	Q93100	100	35	76	19/17	木箱	58x18x16.5
Q93160	Q93160	160	50	100	54/47	木箱	73x28x20

Q13(QB) SERIES MACHINE VICE / Q13(QB)系列平口钳

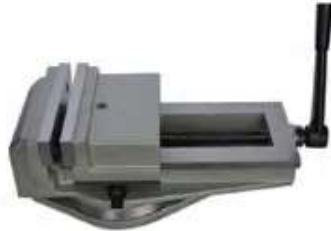

货号 Order No.	型号 Model	钳口宽度 Width of Jaw mm	钳口高度 Height of Jaw mm	钳口开口度 Max. Opening mm	毛重/净重 GW./NW. kg	装箱数量 Q' TY	包装尺寸(mm) Packing Size
Q13136	Q13136	135	36	170	17/16	1	450x200x180
Q13160	Q13160	160	51	180	27/26	1	450x200x200
Q13200	Q13200	200	64	220	38/37	1	510x240x220
Q13250	Q13250	250	64	280	56/54	1	610x360x250
Q13320	Q13320	320	81	360	81/79	1	740x360x260