

DEAD CENTER / 固定顶尖

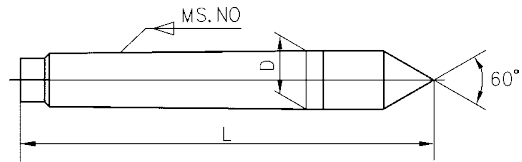

Order No. 货号	Size 型号	MS.NO.	D mm	L mm	重量 Wt(kg)	精度 Accuracy(mm)
6500.0001	DC-DG1	MS1	12.065	80	0.057	0.010
6500.0002	DC-DG2	MS2	17.780	100	0.150	
6500.0003	DC-DG3	MS3	23.825	125	0.334	
6500.0004	DC-DG4	MS4	31.267	160	0.746	
6500.0005	DC-DG5	MS5	44.399	200	1.862	
6500.0006	DC-DG6	MS6	63.348	270	4.925	
6500.0007	DC-DG7	MS7	83.061	360	8.620	

HALF-NOTCHED CENTER / 半缺顶尖

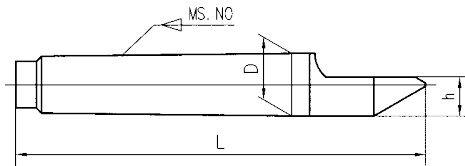

Order No. 货号	Size 型号	MS.NO.	D mm	h mm	L mm	重量 Wt(kg)	精度 Accuracy(mm)
6501.0001	HNC-DH1	MS1	12.065	7.6	80	0.057	0.010
6501.0002	HNC-DH2	MS2	17.780	11	100	0.150	
6501.0003	HNC-DH3	MS3	23.825	15.05	125	0.334	
6501.0004	HNC-DH4	MS4	31.267	20.8	160	0.746	
6501.0005	HNC-DH5	MS5	44.399	29.35	200	1.862	
6501.0006	HNC-DH6	MS6	63.348	41.9	270	4.925	
6501.0007	HNC-DH7	MS7	83.061	53.78	360	8.620	

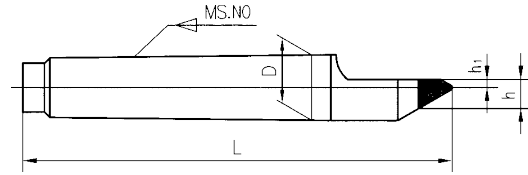
**CARBIDE HALF-NOTCHED CENTER / 硬质合金半缺顶尖**

Order No. 货号	Size 型号	MS.NO.	h <sub>1</sub> mm	h mm	D mm	L mm	重量 Wt(kg)	精度 Accuracy(mm)
6503.0001	CHNC-DHE1	MS1	1.5	5.5	12.065	80	0.06	0.010
6503.0002	CHNC-DHE2	MS2	2	6	17.780	100	0.15	
6503.0003	CHNC-DHE3	MS3	3	9	23.825	125	0.34	
6503.0004	CHNC-DHE4	MS4	5	12.5	31.267	160	0.71	
6503.0005	CHNC-DHE5	MS5	7	16	44.399	200	1.78	
6503.0006	CHNC-DHE6	MS6	10	22	63.348	270	5.00	
6503.0007	CHNC-DHE7	MS7	12	24	83.061	360	8.30	

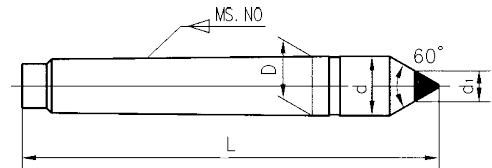
**CARBIDE CENTER / 硬质合金顶尖**

Order No. 货号	Size 型号	MS.NO.	D mm	L mm	d mm	d <sub>1</sub> mm	重量 Wt(kg)	精度 Accuracy(mm)
6502.0001	CBC-DE1	MS1	12.065	80	12.2	8	0.057	0.010
6502.0002	CBC-DE2	MS2	17.780	100	18	8	0.151	
6502.0003	CBC-DE3	MS3	23.825	125	24.1	12	0.335	
6502.0004	CBC-DE4	MS4	31.267	160	31.6	15	0.746	
6502.0005	CBC-DE5	MS5	44.399	200	44.7	18	1.826	
6502.0006	CBC-DE6	MS6	63.348	270	63.8	24	5.230	
6502.0007	CBC-DE7	MS7	83.061	360	83.555	24	9.190	

**BULL NOSE CENTER / 伞形顶尖**

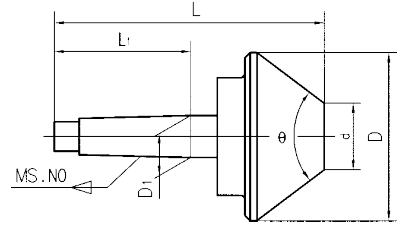

Order No. 货号	Size 型号	MS.NO.	L	L1	D	D1	d	$\theta$
6504.0001	BNC-DS2X60(60°)	MS2	132	64	60	17.780	20	60°
6504.0002	BNC-DS2X61.9(70°)	MS2	135	64	61.9	17.780	12.7	70°
6504.0003	BNC-DS3X76.2(70°)	MS3	152	81	76.2	23.825	19	70°
6504.0004	BNC-DS3X100(60°)	MS3	170	81	100	23.825	30	60°
6504.0005	BNC-DS3X100(75°)	MS3	164	81	100	23.825	32	75°
6504.0006	BNC-DS4X160(60°)	MS4	232	102.5	160	31.267	40	60°
6504.0007	BNC-DS4X160(75°)	MS4	225	102.5	160	31.267	35	75°
6504.0008	BNC-DS5X200(75°)	MS5	252	129.5	200	44.399	40	75°
6504.0009	BNC-DS5X250(75°)	MS5	281	129.5	250	44.399	57	75°
6504.0010	BNC-DS6X200(75°)	MS6	320	182	200	63.348	40	75°
6504.0011	BNC-DS6X250(75°)	MS6	355	182	250	63.348	57	75°

**PRECISION LIVE CENTER/ M11 型精密回转顶尖**

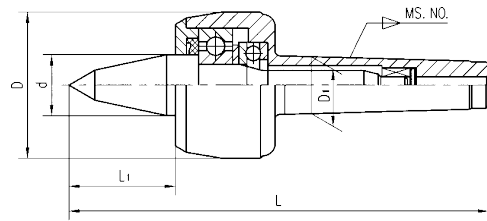

Order No. 货号	Size 型号	MS. NO.	L mm	D mm	L1 mm	d mm	D1 mm	最大载荷(kg) Max Load	极限转速(rpm) Max Speed	精度(mm) Accuracy
6505.0001	PLC-M11/101MS1	MS1	124	36	27	15	12.065	80	7000	0.01
6505.0002	PLC-M11/102MS2	MS2	139	45	34	20	17.780	140	7000	0.005
6505.0003	PLC-M11/106MS3	MS3	176.5	60	47	25	23.825	400	5000	0.005
6505.0004	PLC-M11/108MS4	MS4	217	70	53	32	31.267	500	3800	0.005
6505.0005	PLC-M11/110MS5	MS5	273	90	65	40	44.399	1200	3000	0.005
6505.0006	PLC-M11/114MS6	MS6	354.5	105	78	50	63.348	2500	2600	0.01

## PRECISION LIVE CENTER / 604H 型精密回转顶尖

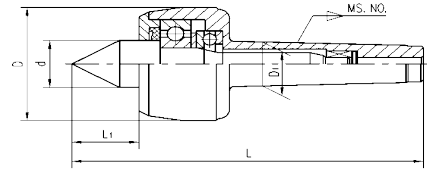

Order No. 货号	Size 型号	MS. NO.	L mm	D mm	L <sub>1</sub> mm	d mm	D <sub>1</sub> mm	最大载荷(kg) Max Load	极限转速(rpm) Max Speed	精度(mm) Accuracy
6506.0001	PLC-604H/101	MS1	114	36	17	15	12.065	100	7000	0.010
6506.0002	PLC-604H/102	MS2	129	45	24	20	17.780	200	7000	0.005
6506.0003	PLC-604H/104	MS3	151.5	50	27.5	22	23.825	400	6300	0.005
6506.0004	PLC-604H/106	MS3	160.5	60	31	25	23.825	500	5000	0.005
6506.0005	PLC-604H/108	MS4	205	70	41	32	31.267	800	3800	0.005
6506.0006	PLC-604H/110	MS5	258.5	90	50.5	40	44.399	2000	3000	0.005
6506.0007	PLC-604H/114	MS6	334	105	57.5	50	63.348	3500	2600	0.010
6506.0008	PLC-604H/116	MS6	378	140	67	60	63.348	4500	1500	0.010
6506.0009	PLC-604H/116E	ME80	392	140	68	60	80	7500	1500	0.010

## PRECISION LIGHT-DUTY LIVE CENTER / 精密轻型回转顶尖

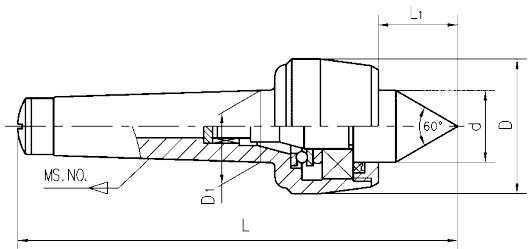

Order No. 货号	Size 型号	MS. NO.	L mm	D mm	L <sub>1</sub> mm	d mm	D <sub>1</sub> mm	径向载荷(N) Max Radial Load	极限转速(rpm) Max Speed	精度(mm) Accuracy
6507.0001	PLDC-DM311	MS1	115	34	20.3	18	12.065	320	5000	0.005
6507.0002	PLDC-DM312	MS2	129.6	45	28.6	25	17.780	400	5000	0.006
6507.0003	PLDC-DM313	MS3	160.2	52	32	28	23.825	800	4500	0.006
6507.0004	PLDC-DM314	MS4	191.7	60	36.5	32	31.267	1250	3500	0.006
6507.0005	PLDC-DM315	MS5	244.5	80	50.8	45	44.399	1500	3000	0.006
6507.0006	PLDC-DM316	MS6	350	130	74.8	75	63.348	1800	2500	0.006
6507.0007	PLDC-DM317	MS7	423.5	130	74.8	75	83.061	2200	2000	0.006

## HIGH-SPEED LIVE CENTER

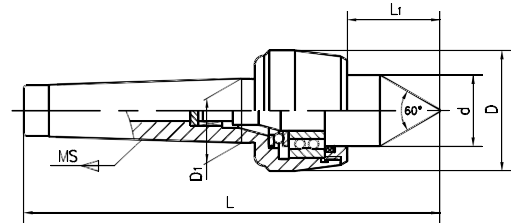

Order No. 货号	Size 型号										
6508.0001	HSLC-HD313	MS3	180	53	39	30	23.825	500Kg	5000	±0.003	
6508.0002	HSLC-HD314	MS4	208	63	42	32	31.267	800Kg	4500	±0.003	
6508.0003	HSLC-HD315	MS5	256	83	49	40	44.399	1600Kg	3500	±0.003	

## MEDIUM-DUTY LIVE CENTER

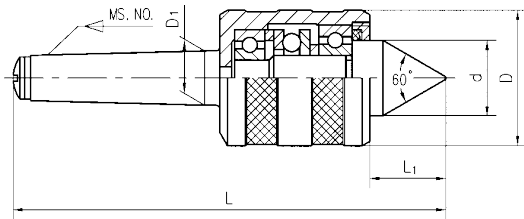

Order No. 货号	Size 型号										
6509.0001	MDLC-D411	MS1	115	20	34	18	12.065	900	5000	0.29	0.01
6509.0002	MDLC-D412	MS2	145	26	45	25	17.780	1500	5000	0.70	0.01
6509.0003	MDLC-D413	MS3	170	30	52	28	23.825	2000	4200	0.93	0.01
6509.0004	MDLC-D414	MS4	205.7	34.7	60	32	31.267	3200	3200	1.70	0.01
6509.0005	MDLC-D415	MS5	254	45	77	45	44.399	6300	2400	3.39	0.015
6509.0006	MDLC-D416	MS6	362	68.5	125	75	63.348	10000	1600	12.00	0.015
6509.0007	MDLC-D411L	MS1	125	30	34	18	12.065	900	5000	0.31	0.01
6509.0008	MDLC-D412L	MS2	155	36	45	25	17.780	1500	5000	0.74	0.01
6509.0009	MDLC-D413L	MS3	183	43	52	28	23.825	2000	4200	0.99	0.01
6509.0010	MDLC-D414L	MS4	222	51	60	32	31.267	3200	3200	1.80	0.01
6509.0011	MDLC-D415L	MS5	272	63	77	45	44.399	6300	2400	3.62	0.015
6509.0012	MDLC-D416L	MS6	382	88.5	125	75	63.348	10000	1600	12.69	0.015

**CARBIDE MEDIUM-DUTY LIVE CENTER / 硬质合金中型回转顶尖**

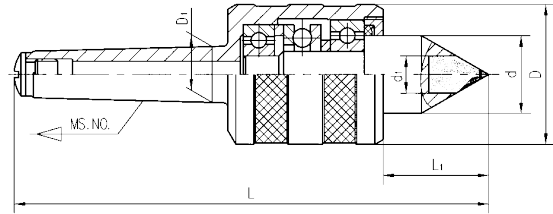

Order No. 货号	Size 型号	MS. NO.	L mm	D mm	L <sub>1</sub> mm	d mm	D <sub>1</sub> mm	d <sub>1</sub> mm	最大载荷(N) Max Load	极限转速(rpm) Max Speed	精度(mm) Accuracy
6510.0001	CMDLC-D412A	MS2	145	45	26	25	17.780	12	1500	5000	0.010
6510.0002	CMDLC-D413A	MS3	170	52	30	28	23.825	15	2000	4200	0.010
6510.0003	CMDLC-D414A	MS4	205.7	60	34.7	32	31.267	18	3200	3200	0.010
6510.0004	CMDLC-D415A	MS5	254	77	45	45	44.399	24	6300	2000	0.015
6510.0005	CMDLC-D416A	MS6	362	125	68.5	75	63.348	40	10000	1600	0.015

**MEDIUM-DUTY MULTI-PURPOSE LIVE CENTER / 插入式回转顶尖**

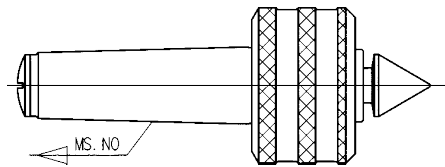

A:  $\alpha=60^\circ$   
B:  $\alpha=75^\circ$   
C:  $\alpha=90^\circ$

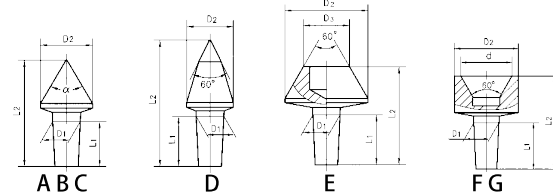

Order No. 货号	Size 型号	MS. NO.	D <sub>1</sub>	L <sub>1</sub>	A		B		C		D		E		F		G		重量 Wt(kg)			
					D <sub>2</sub>	L <sub>2</sub>	D <sub>2</sub>	L <sub>2</sub>	D <sub>2</sub>	L <sub>2</sub>	D <sub>2</sub>	L <sub>2</sub>	D <sub>2</sub>	D <sub>3</sub>	L <sub>2</sub>	D <sub>2</sub>	L <sub>2</sub>	d		D <sub>2</sub>	L <sub>2</sub>	d
6511.0001	MDPC-D432	MS2	10	20	16	39	16	35.5	16	33	16	46	25	10	40	16	36	10	20	39	16	0.95
6511.0002	MDPC-D433	MS3	12	24	20	48	20	43.5	20	40.5	18	56	35	15	50	22	42	18	35	48	30	1.87
6511.0003	MDPC-D434	MS4	15	30	28	61.5	28	55.5	28	51.5	26	73	55	30	61.5	40	55	35	55	60	48	2.42
6511.0004	MDPC-D435	MS5	20	40	36	80	36	72.45	36	66.8	36	101	70	41	78	60	81	50	70	85	61	4.12
6511.0005	MDPC-D436	MS6	30	55	55	117	55	113	55	108	50	138	90	50	107.5	75	110	60	90	116	75	7.83

HIGH-SPEED MEDIUM-DUTY MULTI-PURPOSE LIVE CENTER / 高速插入式回转顶尖

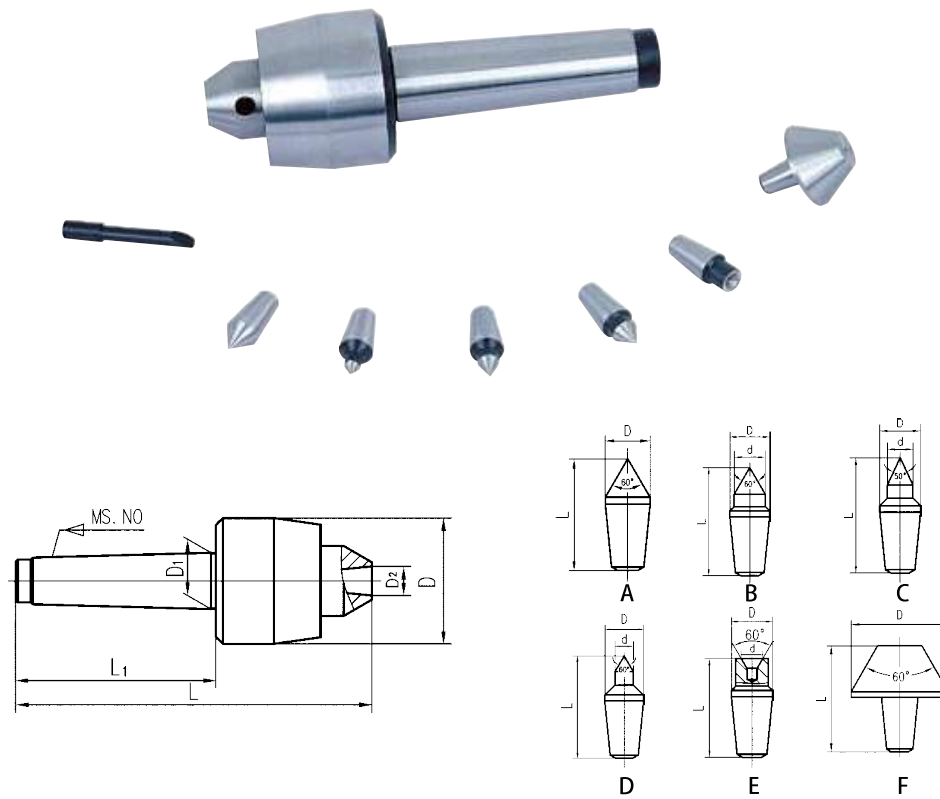

Order No. 货号	Size 型号	MS. NO.	D mm	D1 mm	L1 mm	L mm
6512.0001	HSPC-HD432	MS2	48	17.780	69	127
6512.0002	HSPC-HD433	MS3	54	23.825	86	153
6512.0003	HSPC-HD434	MS4	63	31.267	109	182
6512.0004	HSPC-HD435	MS5	83	44.399	136	217

MS.NO.	A		B			C			D			E			F	
	L	D	L	D	d	L	D	d	L	D	d	L	D	d	L	D
2	26	10.2	28.5	10.2	8	29	10.2	6.5	27.5	10.2	5	25	10.2	5.3	30	28
3	32	12.75	35	12.75	10	36	12.75	8	34	12.75	6	31	12.75	6.7	37	34
4																
5	39	15.7	44	15.7	12	45	15.7	10	42	15.7	8	43	15.7	8.5	48	40

## PRECISION HEAVY LIVE CENTER / 精密重型回转顶尖

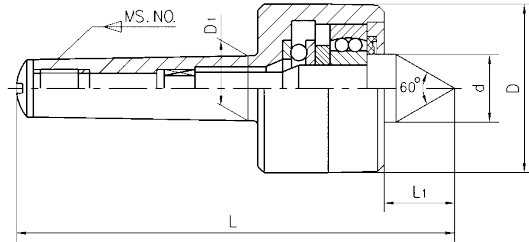

Order No. 货号	Size 型号	MS. NO.	L mm	D mm	L <sub>1</sub> mm	d mm	D <sub>1</sub> mm	径向载荷(N) Max Radial Load	极限转速(rpm) Max Speed	重量 Wt(kg)	精度(mm) Accuracy
6513.0001	PHLC-DM511	MS1	109.6	38	18.5	16	12.065	1400	3600	0.29	0.008
6513.0002	PHLC-DM512	MS2	128.5	48	24	22	17.780	3500	3400	0.39	0.010
6513.0003	PHLC-DM513	MS3	156	58	28.5	25	23.825	5500	3200	1.09	0.010
6513.0004	PHLC-DM514	MS4	192.5	68	31.5	28	31.267	8000	3000	1.69	0.010
6513.0005	PHLC-DM515	MS5	245	90	45	41	44.399	10000	2500	4.00	0.012
6513.0005	PHLC-DM516	MS6	342.5	130	64	63	63.348	15000	1500	11.61	0.015

## MEDIUM-DUTY LIVE CENTER (EXTENDED) / 中型回转顶尖(加长型)

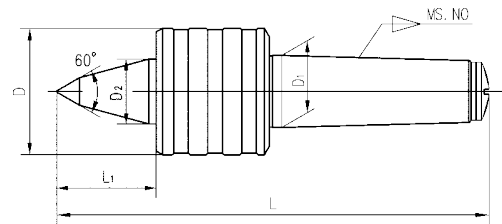

Order No. 货号	Size 型号	MS.NO.	L <sub>1</sub> mm	D mm	D <sub>1</sub> mm	D <sub>2</sub> mm	L mm	重量 Wt(kg)
6514.0001	MDLC-D412B	MS2	28.5	40	17.780	18	141	0.84
6514.0002	MDLC-D413B	MS3	36.5	45	23.825	22	168	0.91
6514.0003	MDLC-D414B	MS4	36.5	45	31.267	22	190	1.62
6514.0004	MDLC-D415B	MS5	62	78	44.399	40	267.5	3.43
6514.0005	MDLC-D416B	MS6	75	102	63.348	50	346.5	11