

Retaining Screws / 十字压紧螺栓

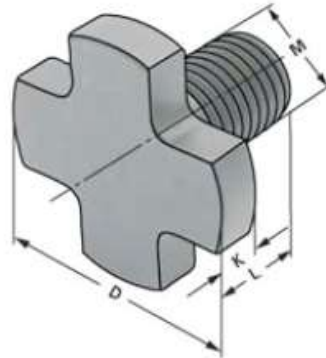

Order No. 货号	Size 规格	Size 尺寸	M	D	K	L
5500.2016	RS-FM16-M8	16	M8	20	6	16
5500.2022	RS-FM22-M10	22	M10	28	7	18
5500.2027	RS-FM27-M12	27	M12	35	8	22
5500.2032	RS-FM32-M16	32	M16	42	6	26
5500.2040	RS-FM40-M20	40	M20	52	10	30
5500.2050	RS-FM50-M24	50	M24	63	12	36
5500.2060	RS-FM60-M30	60	M30	75	14	45

Retaining Screws with Drill Through for Coolant / 十字压紧螺栓(带冷却)

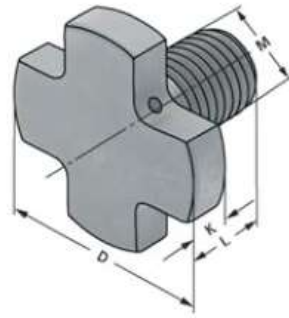

Order No. 货号	Size 规格	Size 尺寸	M	D	K	L
5500.1016	RS-FM16-M8-IC	16	M8	20	6	16
5500.1022	RS-FM22-M10-IC	22	M10	28	7	18
5500.1027	RS-FM27-M12-IC	27	M12	35	8	22
5500.1032	RS-FM32-M16-IC	32	M16	42	6	26
5500.1040	RS-FM40-M20-IC	40	M20	52	10	30
5500.1050	RS-FM50-M24-IC	50	M24	63	12	36
5500.1060	RS-FM60-M30-IC	60	M30	75	14	45