

数显测微头

Digital Micrometer Head

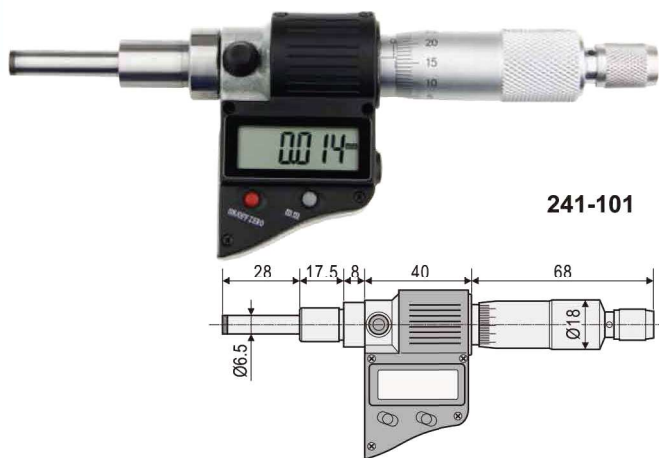

241-101



241-201



241-201C

241-201B

241-201A

主要特点:

- 设定初始值、测量单位转换、绝对/相对测量转换、数据输出
- 硬质合金测量面，保证设备持久的稳定性
- 内置式限力装置，确保精确的重复读数

FEATURES

- Origin setting, mm/inch conversion, switch of absolute measurement and incremental measurement, data output
- Cemented carbide measuring surface ensures the constant stabilization of the equipment
- Built-in force limiting device ensures accuracy of repeat reading

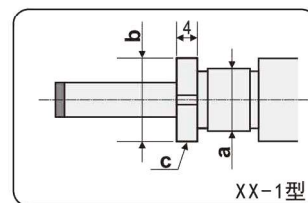

XX-1型

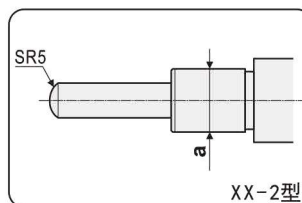

XX-2型

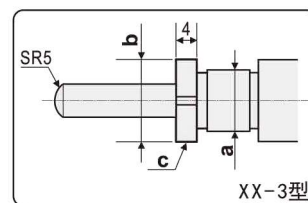

XX-3型

货号 Code NO.	测量范围 Measuring Range mm	分辨率 Resolution mm	精度 Accuracy mm	a mm	b mm	c mm
241-101	0-25	0.001	0.003	Ø12	—	—
241-101-1	0-25	0.001	0.003	Ø12	Ø16	M12x0.5
241-101-2	0-25	0.001	0.003	Ø12	—	—
241-101-3	0-25	0.001	0.003	Ø12	Ø16	M12x0.5
241-101A	0-25	0.001	0.003	Ø10	—	—
241-101A-1	0-25	0.001	0.003	Ø10	Ø14	M9.5x0.5
241-101A-2	0-25	0.001	0.003	Ø10	—	—
241-101A-3	0-25	0.001	0.003	Ø10	Ø14	M9.5x0.5
241-201	0-25	0.001	0.003	Ø12	—	—
241-201-1	0-25	0.001	0.003	Ø12	Ø16	M12x0.5
241-201-2	0-25	0.001	0.003	Ø12	—	—
241-201-3	0-25	0.001	0.003	Ø12	Ø16	M12x0.5
241-201A	0-18	0.001	0.003	—	—	—
241-201B	0-18	0.001	0.003	—	—	—
241-201C	0-28	0.001	0.003	—	—	—



千分尺座

Micrometer Stand



722-101LT

主要特点:

- 夹持范围0-100mm千分尺
- 夹持张口15mm

FEATURES

- Accommodates 0-100mm micrometers
- Mouth width is 15mm