

奇数沟游标卡尺

Precision 3-point and 5-point Vernier Caliper

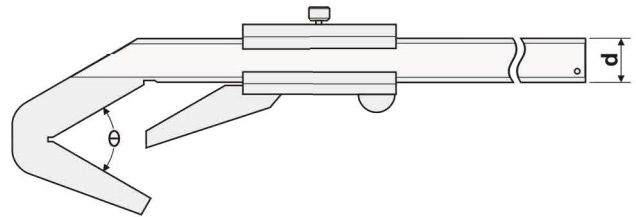
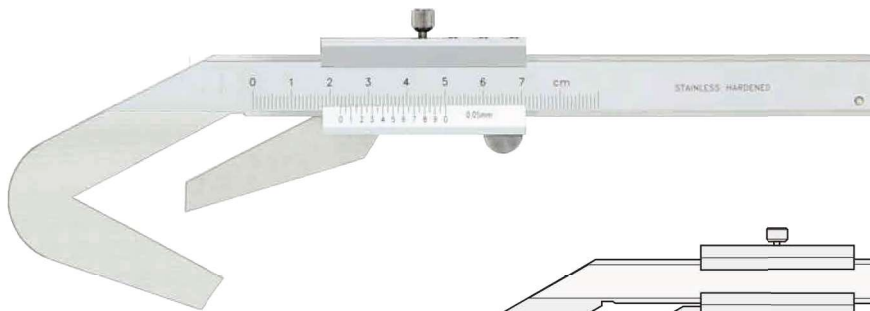

主要特点:

- 用于测量3沟、5沟的铣刀外径尺寸

FEATURES

- Used for measuring the OD of milling cutter with Three or Five cutting edges

货号 Code NO.	测量范围 Measuring Range mm	分度值 Graduation mm	精度 Accuracy mm	沟数 3-point And 5-point	θ	d mm
142-510	4-40	0.05	± 0.05	3	60°	16
142-520	1-40	0.05	± 0.05	5	108°	16

F

T型划线游标卡尺

T Type Scribing Vernier Caliper

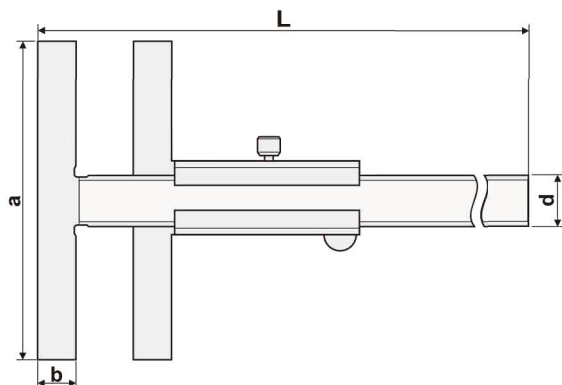
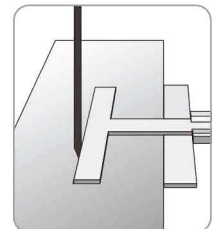
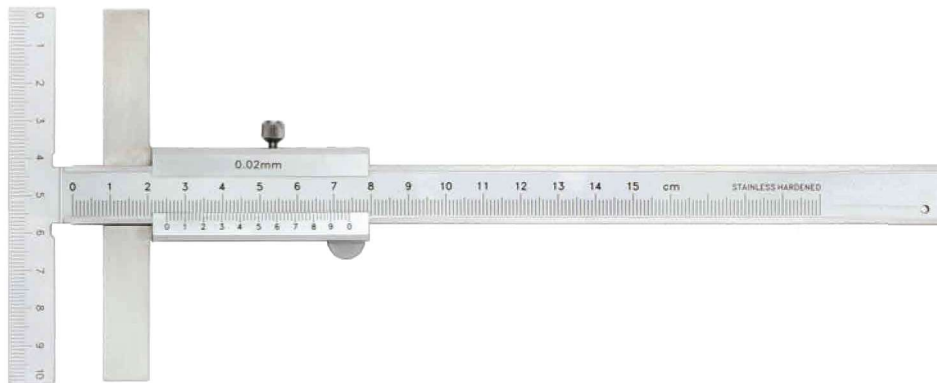

主要特点:

- 便于在工件上划线
- 可测量深度尺寸

FEATURES

- Easy for scribing
- For depth measuring

货号 Code NO.	测量范围 Measuring Range mm	分度值 Graduation mm	精度 Accuracy mm	L mm	a mm	b mm	d mm
159-302	0-150	0.02	± 0.04	250	100	12	16
159-304	0-200	0.02	± 0.04	300	100	12	16
159-306	0-300	0.02	± 0.04	400	100	12	16