

双宽量面数显卡尺

Digital Caliper with Large-sized Measuring Faces

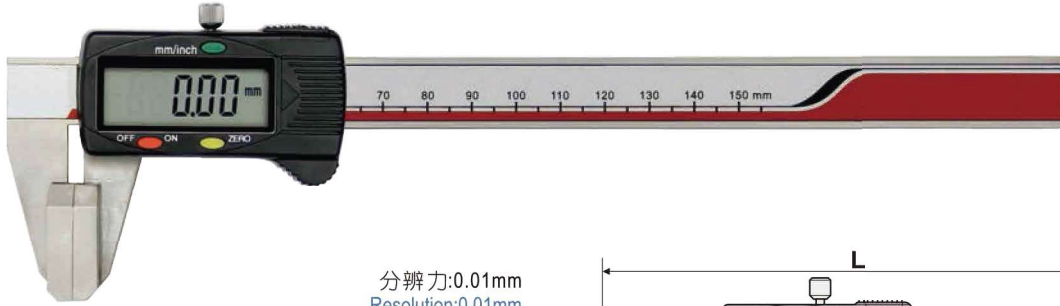

分辨率:0.01mm
Resolution:0.01mm

主要特点:

- 用于测量表面跨度大的工件，如钢丝绳等
- 用于测量表面较软的工件，如海绵、橡胶等

FEATURES

- Used for measuring work piece with wide surface, like wire rope
- Used for measuring work piece with soft surface, like foam and rubber

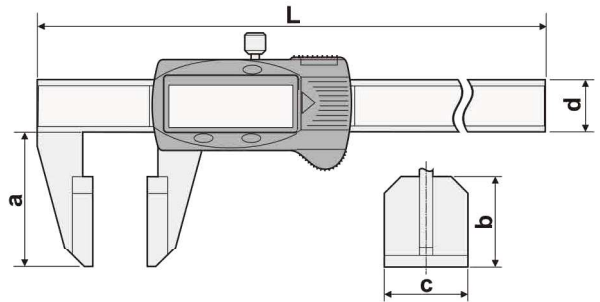

货号 Code NO.	测量范围 Measuring Range mm	精度 Accuracy mm	L mm	a mm	b mm	c mm	d mm
111-901	0-150	±0.05	245	40	27	25	16

F

刀口形数显卡尺

Digital Caliper with Knife-edged Measuring Jaws



分辨率:0.01mm
Resolution:0.01mm

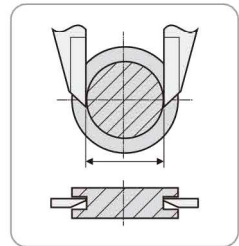

主要特点:

- 用于测量窄小的槽
- 圆形/扁形测深杆可选
- 任意位置清零，便于相对测量与绝对测量转换
- 任意位置公制与英制转换

FEATURES

- Used for narrow groove measurements
- Round and flat depth bar for option
- Zero-setting at any position, convenient for relative and absolute measure conversion
- Mm/inch conversion at any position

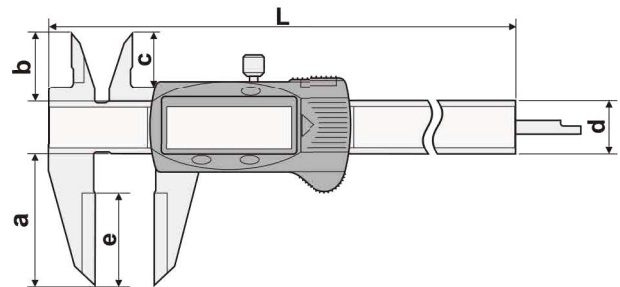

货号 Code NO.	测量范围 Measuring Range mm	精度 Accuracy mm	L mm	a mm	b mm	c mm	d mm	e mm
111-641	0-150	±0.03	236	40	21	16.5	16	28
111-642	0-200	±0.03	286	50	21	19.5	16	36
111-643	0-300	±0.04	400	60	26	21.5	16	44