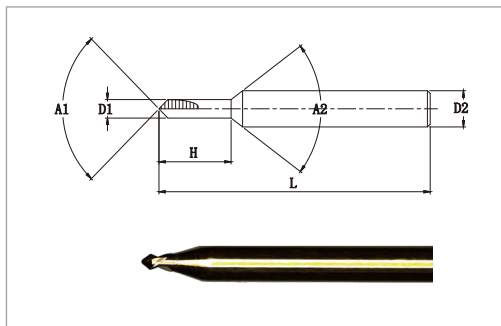

DCC636

王者系列

硬质合金左旋涂层定点钻

FIXED POINT DRILL WITH CEMENTED CARBIDE LEFT-HANDED COATING

直径范围: $\Phi 0.5$ - $\Phi 3.0$ mm直径公差: $+0, -0.005$ mm

单位: (mm)

- ◆ 采用超硬合金圆棒
Using super hard alloy round bar.
- ◆ 耐磨性, 孔径稳定, 寿命长
Wear resistance, stable aperture and long service life.
- ◆ 特别设计的左旋槽形, 适合于自动车床孔的定点加工
The specially designed left-hand groove is suitable for fixed-point machining of automatic lathe holes.
- ◆ 通用性涂层, 适用不锈钢, 钛合金等材料的孔定点加工
Universal coating, suitable for stainless steel, titanium alloy and other materials.

商品号 EDP NO.	直径 D1	刃长 H	柄径 D	全长 L
C636-0500	0.50	2.0	3	30
C636-0600	0.60	2.0	3	30
C636-0700	0.70	2.0	3	30
C636-0800	0.80	2.0	3	30
C636-0900	0.90	2.0	3	30
C636-1000	1.00	2.0	3	30
C636-1250	1.25	2.5	3	30
C636-1300	1.30	2.5	3	30
C636-1330	1.33	2.5	3	30
C636-1350	1.35	2.5	3	30
C626-1380	1.38	2.5	3	30
C636-1400	1.40	2.5	3	30
C636-1500	1.50	2.5	3	30
C636-1550	1.55	2.5	3	30
C636-1600	1.60	2.5	3	30
C636-1650	1.65	2.5	3	30
C636-1700	1.70	2.5	3	30
C636-1750	1.75	2.5	3	30
C636-1800	1.80	2.5	3	30
C636-1850	1.85	2.5	3	30
C636-1900	1.90	2.5	3	30
C636-2000	2.00	2.5	3	30
C636-2500	2.50	2.5	3	30
C636-3000	3.00	2.5	3	30

可切削材料 (● 最适合 ● 适合)

碳素钢 S45C S55C	合金钢 SK·SCM SUS	预硬钢 NAK HPM	淬火钢 ~55HRC ~60HRC ~70HRC			
●	●	●	●			
铸铁	钛合金	高温合金	铜合金	铝合金	树脂	工程塑料
●	●	●	●	●	●	●
玻璃纤维	电木	石墨	氧化锆	单晶硅	陶瓷	碳纤维
●	●					