

# DCC336

## 硬质合金涂层定点钻

FIXED POINT DRILL WITH CEMENTED CARBIDE COATING



直径范围:  $\Phi 0.10$ - $\Phi 10.0$ mm

直径公差: +0, -0.005mm

- ◆ 切入性好, 可进行高精度定位  
Good cut in, high precision positioning.
- ◆ 锋利的切削钻尖确保优质的加工面  
Sharp cutting point ensures high quality machining surface.
- ◆ 功能多样化, 除定点外可进行倒角, V槽加工等多用途  
Function diversification, in addition to fixed-point, can be chamfered, V groove processing and other multi-purpose.

### 可切削材料 ( ● 最适合 ● 适合)

碳素钢 S45C S55C	合金钢 SK·SCM SUS	预硬钢 NAK HPM	淬火钢 ~55HRC ~60HRC ~70HRC			
●	●	●	●	●		
铸铁	钛合金	高温合金	铜合金	铝合金	树脂	工程塑料
●	●	●	●	●	●	●
玻璃纤维	电木	石墨	氧化锆	单晶硅	陶瓷	碳纤维
●	●					

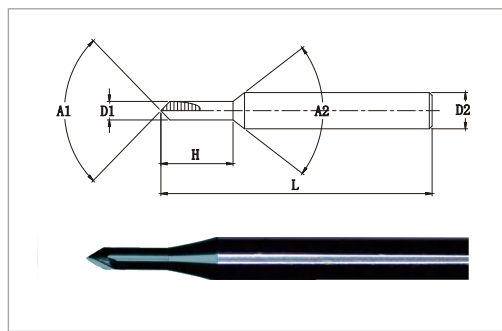

单位: (mm)

商品号 EDP NO.	直径 D1	刃长 H	柄径 D	全长 L
C336-0100	0.10	0.5	3	38
C336-0150	0.15	1.0	3	38
C336-0200	0.20	1.0	3	38
C336-0300	0.30	2.0	3	38
C336-0400	0.40	2.0	3	38
C336-0500	0.50	3.0	3	38
C336-0600	0.60	3.0	3	38
C336-0700	0.70	3.0	3	38
C336-0800	0.80	3.0	3	38
C336-0900	0.90	3.0	3	38
C336-1000	1.00	3.0	3	38
C336-1500	1.50	3.0	3	38
C336-2000	2.00	3.0	3	38
C336-2500	2.50	3.0	3	38
C336-3000	3.00	3.0	3	38
C336-3500	3.50	5.0	4	50
C336-4000	4.00	5.0	4	50
C336-4500	4.50	5.0	6	50
C336-5000	5.00	5.0	6	50
C336-5500	5.50	5.0	6	50
C336-6000	6.00	5.0	6	50
C336-6500	6.50	8.0	8	80
C336-7000	7.00	8.0	8	80
C336-7500	7.50	8.0	8	80
C336-8000	8.00	8.0	8	80
C336-8500	8.50	8.0	10	80
C336-9000	9.00	8.0	10	80
C336-9500	9.50	8.0	10	80
C336-10000	10.00	8.0	10	80