

## MFR □ B□L□

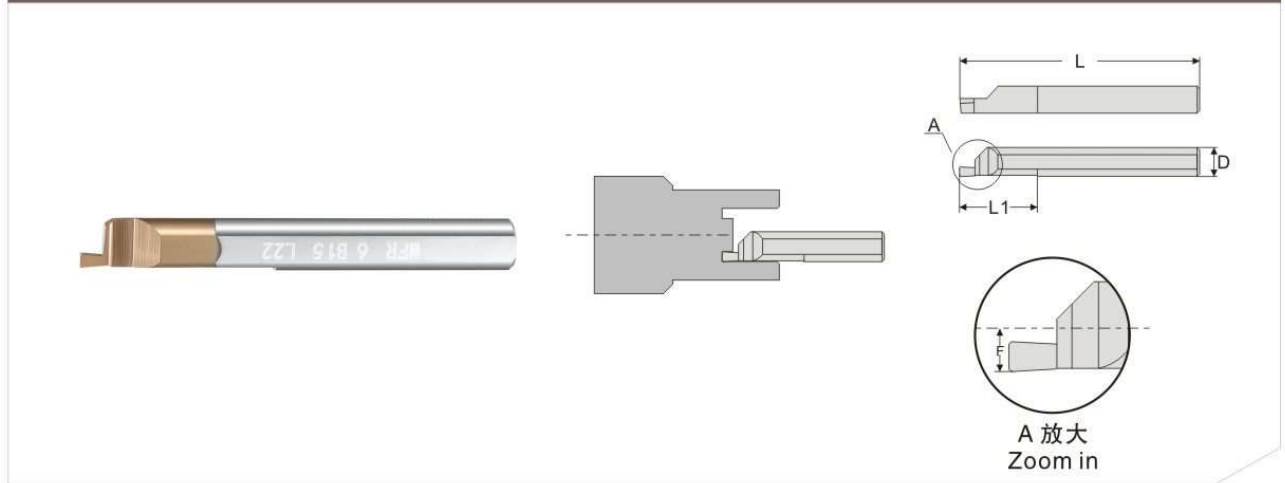

### 技术参数(Technical parameters):

D	MODEL	L	L1	R	F	最小孔径 Minimum bore diameter
4.0	MFR 4 B1.0 L10	50	10	0.15	1.8	5.0
	MFR 4 B1.0 L15	50	15	0.15	1.8	5.0
5.0	MFR 5 B1.0 L15	50	15	0.15	2.3	6.0
	MFR 5 B1.0 L22	50	22	0.15	2.3	6.0
	MFR 5 B1.5 L15	50	15	0.15	2.3	6.0
	MFR 5 B1.5 L22	50	22	0.15	2.3	6.0
6.0	MFR 6 B1.0 L15	50	15	0.15	2.8	8.0
	MFR 6 B1.0 L22	50	22	0.15	2.8	8.0
	MFR 6 B1.5 L15	50	15	0.15	2.8	8.0
	MFR 6 B1.5 L22	50	22	0.15	2.8	8.0
	MFR 6 B2.0 L15	50	15	0.2	2.8	8.0
	MFR 6 B2.0 L22	50	22	0.2	2.8	8.0