

DIN 6388 B Collets OZ / OZ弹簧夹头

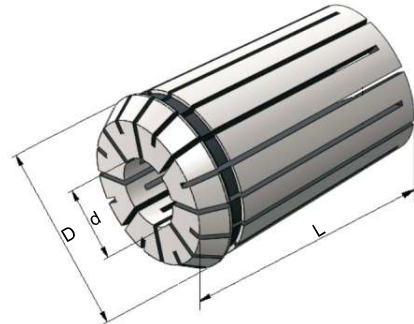

standard
标准型

Order No. (S) 货号 (标准型)	Size 规格	d 夹持直径	D	L
1116.0002	OZ16-02	1.5-2	25.5	40
1116.0003	OZ16-03	2.5-3	25.5	40
1116.0004	OZ16-04	3.5-4	25.5	40
1116.0005	OZ16-05	4.5-5	25.5	40
1116.0006	OZ16-06	5.5-6	25.5	40
1116.0007	OZ16-07	6.5-7	25.5	40
1116.0008	OZ16-08	7.5-8	25.5	40
1116.0009	OZ16-09	8.5-9	25.5	40
1116.0010	OZ16-10	9.5-10	25.5	40
1116.0011	OZ16-11	10.5-11	25.5	40
1116.0012	OZ16-12	11.5-12	25.5	40
1116.0013	OZ16-13	12.5-13	25.5	40
1116.0014	OZ16-14	13.5-14	25.5	40
1116.0015	OZ16-15	14.5-15	25.5	40
1116.0016	OZ16-16	15.5-16	25.5	40

DIN 6388 B Collets OZ / OZ 弹簧夹头

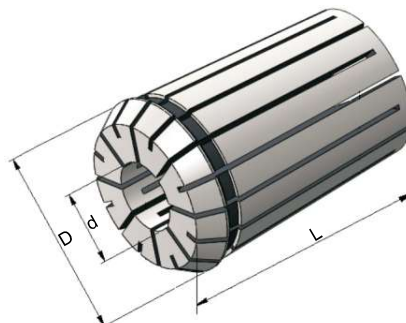
 precision
 高精密型

Order No. (S) 货号 (标准型)	Size 规格	d 夹持直径	D	L
1116P.0002	OZ16-02-P	1.5-2	25.5	40
1116P.0003	OZ16-03-P	2.5-3	25.5	40
1116P.0004	OZ16-04-P	3.5-4	25.5	40
1116P.0005	OZ16-05-P	4.5-5	25.5	40
1116P.0006	OZ16-06-P	5.5-6	25.5	40
1116P.0007	OZ16-07-P	6.5-7	25.5	40
1116P.0008	OZ16-08-P	7.5-8	25.5	40
1116P.0009	OZ16-09-P	8.5-9	25.5	40
1116P.0010	OZ16-10-P	9.5-10	25.5	40
1116P.0011	OZ16-11-P	10.5-11	25.5	40
1116P.0012	OZ16-12-P	11.5-12	25.5	40
1116P.0013	OZ16-13-P	12.5-13	25.5	40
1116P.0014	OZ16-14-P	13.5-14	25.5	40
1116P.0015	OZ16-15-P	14.5-15	25.5	40
1116P.0016	OZ16-16-P	15.5-16	25.5	40

DIN 6388 B Collets OZ / OZ 弹簧夹头

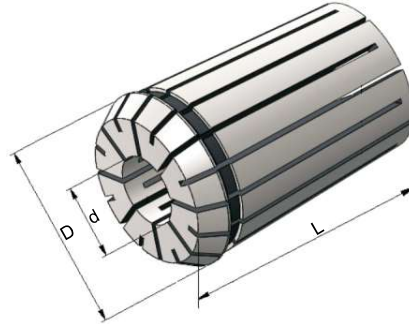
 standard
标准型

Order No. (S) 货号 (标准型)	Size 规格	d 夹持直径	D	L
1125.0002	OZ25-02	1.5-2	35.05	52
1125.0003	OZ25-03	2.5-3	35.05	52
1125.0004	OZ25-04	3.5-4	35.05	52
1125.0005	OZ25-05	4.5-5	35.05	52
1125.0006	OZ25-06	5.5-6	35.05	52
1125.0007	OZ25-07	6.5-7	35.05	52
1125.0008	OZ25-08	7.5-8	35.05	52
1125.0009	OZ25-09	8.5-9	35.05	52
1125.0010	OZ25-10	9.5-10	35.05	52
1125.0011	OZ25-11	10.5-11	35.05	52
1125.0012	OZ25-12	11.5-12	35.05	52
1125.0013	OZ25-13	12.5-13	35.05	52
1125.0014	OZ25-14	13.5-14	35.05	52
1125.0015	OZ25-15	14.5-15	35.05	52
1125.0016	OZ25-16	15.5-16	35.05	52
1125.0017	OZ25-17	16.5-17	35.05	52
1125.0018	OZ25-18	17.5-18	35.05	52
1125.0019	OZ25-19	18.5-19	35.05	52
1125.0020	OZ25-20	19.5-20	35.05	52
1125.0021	OZ25-21	20.5-21	35.05	52
1125.0022	OZ25-22	21.5-22	35.05	52
1125.0023	OZ25-23	22.5-23	35.05	52
1125.0024	OZ25-24	23.5-24	35.05	52
1125.0025	OZ25-25	24.5-25	35.05	52

DIN 6388 B Collets OZ / 高精度OZ弹簧夹头

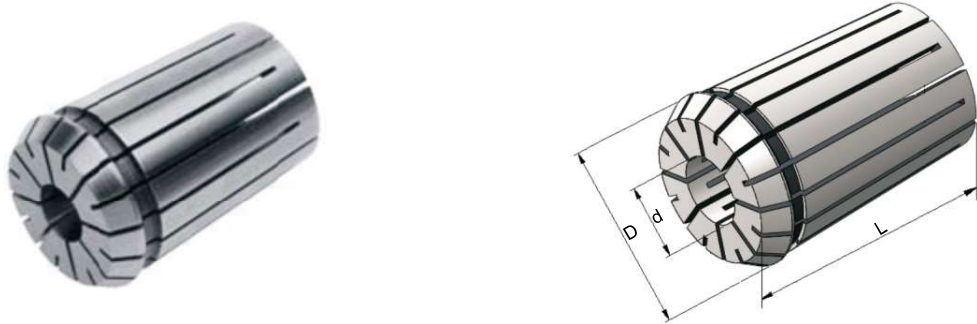

 precision
 高精密型

Order No. (S) 货号 (标准型)	Size 规格	d 夹持直径	D	L
1125P.0002	OZ25-02-P	1.5-2	35.05	52
1125P.0003	OZ25-03-P	2.5-3	35.05	52
1125P.0004	OZ25-04-P	3.5-4	35.05	52
1125P.0005	OZ25-05-P	4.5-5	35.05	52
1125P.0006	OZ25-06-P	5.5-6	35.05	52
1125P.0007	OZ25-07-P	6.5-7	35.05	52
1125P.0008	OZ25-08-P	7.5-8	35.05	52
1125P.0009	OZ25-09-P	8.5-9	35.05	52
1125P.0010	OZ25-10-P	9.5-10	35.05	52
1125P.0011	OZ25-11-P	10.5-11	35.05	52
1125P.0012	OZ25-12-P	11.5-12	35.05	52
1125P.0013	OZ25-13-P	12.5-13	35.05	52
1125P.0014	OZ25-14-P	13.5-14	35.05	52
1125P.0015	OZ25-15-P	14.5-15	35.05	52
1125P.0016	OZ25-16-P	15.5-16	35.05	52
1125P.0017	OZ25-17-P	16.5-17	35.05	52
1125P.0018	OZ25-18-P	17.5-18	35.05	52
1125P.0019	OZ25-19-P	18.5-19	35.05	52
1125P.0020	OZ25-20-P	19.5-20	35.05	52
1125P.0021	OZ25-21-P	20.5-21	35.05	52
1125P.0022	OZ25-22-P	21.5-22	35.05	52
1125P.0023	OZ25-23-P	22.5-23	35.05	52
1125P.0024	OZ25-24-P	23.5-24	35.05	52
1125P.0025	OZ25-25-P	24.5-25	35.05	52

DIN 6388 B Collets OZ / OZ 弹簧夹头

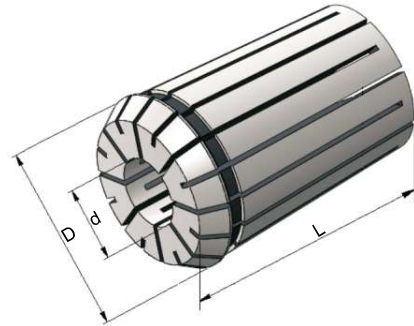

standard
标准型

Order No. (S) 货号 (标准型)	Size 规格	d 夹持直径	D	L
1132.0003	OZ32-03	2.5-3	43.07	60
1132.0004	OZ32-04	3.5-4	43.07	60
1132.0005	OZ32-05	4.5-5	43.07	60
1132.0006	OZ32-06	5.5-6	43.07	60
1132.0007	OZ32-07	6.5-7	43.07	60
1132.0008	OZ32-08	7.5-8	43.07	60
1132.0009	OZ32-09	8.5-9	43.07	60
1132.0010	OZ32-10	9.5-10	43.07	60
1132.0011	OZ32-11	10.5-11	43.07	60
1132.0012	OZ32-12	11.5-12	43.07	60
1132.0013	OZ32-13	12.5-13	43.07	60
1132.0014	OZ32-14	13.5-14	43.07	60
1132.0015	OZ32-15	14.5-15	43.07	60
1132.0016	OZ32-16	15.5-16	43.07	60
1132.0017	OZ32-17	16.5-17	43.07	60
1132.0018	OZ32-18	17.5-18	43.07	60
1132.0019	OZ32-19	18.5-19	43.07	60
1132.0020	OZ32-20	19.5-20	43.07	60
1132.0021	OZ32-21	20.5-21	43.07	60

DIN 6388 B Collets OZ / OZ 弹簧夹头

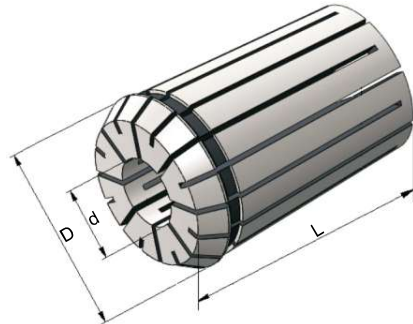

standard
标准型

Order No. (S) 货号 (标准型)	Size 规格	d 夹持直径	D	L
1132.0022	OZ32-22	21.5-22	43.07	60
1132.0023	OZ32-23	22.5-23	43.07	60
1132.0024	OZ32-24	23.5-24	43.07	60
1132.0025	OZ32-25	24.5-25	43.07	60
1132.0026	OZ32-26	25.5-26	43.07	60
1132.0027	OZ32-27	26.5-27	43.07	60
1132.0028	OZ32-28	27.5-28	43.07	60
1132.0029	OZ32-29	28.5-29	43.07	60
1132.0030	OZ32-30	29.5-30	43.07	60
1132.0031	OZ32-31	30.5-31	43.07	60
1132.0032	OZ32-32	31.5-32	43.07	60

DIN 6388 B Collets OZ / OZ 弹簧夹头

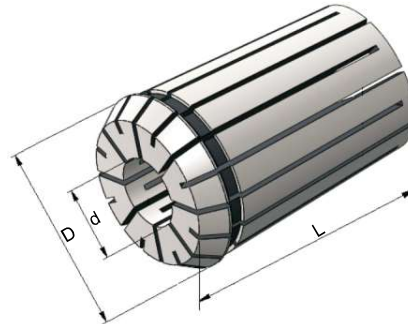

standard
标准型



precision
高精型

Order No. (S) 货号 (标准型)	Size 规格	d 夹持直径	D	L
1132P.0003	OZ32-03-P	2.5-3	43.7	60
1132P.0004	OZ32-04-P	3.5-4	43.7	60
1132P.0005	OZ32-05-P	4.5-5	43.7	60
1132P.0006	OZ32-06-P	5.5-6	43.7	60
1132P.0007	OZ32-07-P	6.5-7	43.7	60
1132P.0008	OZ32-08-P	7.5-8	43.7	60
1132P.0009	OZ32-09-P	8.5-9	43.7	60
1132P.0010	OZ32-10-P	9.5-10	43.7	60
1132P.0011	OZ32-11-P	10.5-11	43.7	60
1132P.0012	OZ32-12-P	11.5-12	43.7	60
1132P.0013	OZ32-13-P	12.5-13	43.7	60
1132P.0014	OZ32-14-P	13.5-14	43.7	60
1132P.0015	OZ32-15-P	14.5-15	43.7	60
1132P.0016	OZ32-16-P	15.5-16	43.7	60
1132P.0017	OZ32-17-P	16.5-17	43.7	60
1132P.0018	OZ32-18-P	17.5-18	43.7	60
1132P.0019	OZ32-19-P	18.5-19	43.7	60
1132P.0020	OZ32-20-P	19.5-20	43.7	60
1132P.0021	OZ32-21-P	20.5-21	43.7	60

DIN 6388 B Collets OZ / 高精密 OZ 弹簧夹头

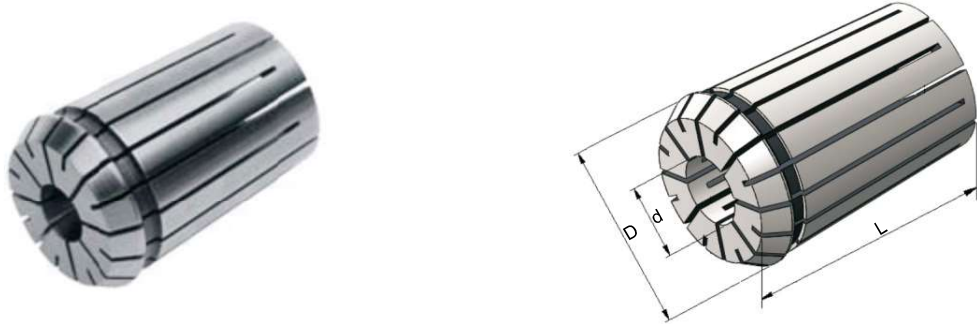

precision
高精密型

Order No. (S) 货号 (标准型)	Size 规格	d 夹持直径	D	L
1132P.0022	OZ32-22-P	21.5-22	43.7	60
1132P.0023	OZ32-23-P	22.5-23	43.7	60
1132P.0024	OZ32-24-P	23.5-24	43.7	60
1132P.0025	OZ32-25-P	24.5-25	43.7	60
1132P.0026	OZ32-26-P	25.5-26	43.7	60
1132P.0027	OZ32-27-P	26.5-27	43.7	60
1132P.0028	OZ32-28-P	27.5-28	43.7	60
1132P.0029	OZ32-29-P	28.5-29	43.7	60
1132P.0030	OZ32-30-P	29.5-30	43.7	60
1132P.0031	OZ32-31-P	30.5-31	43.7	60
1132P.0032	OZ32-32-P	31.5-32	43.7	60