

U钻 (U-Drill)

带定心钻头 深孔钻 8D Spotting U-drill 8D

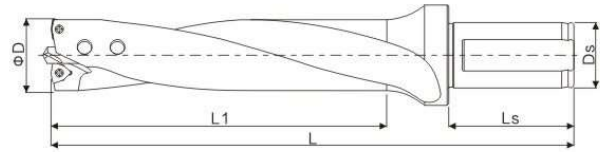

规格型号 Specification and model	D	L1	L	Ds	Ls	刀片型号 Insert model	螺钉 Screw	扳手 Wrench	库存 Stock
VLT-21080D S25	21	168	247	25	56	WCMX030208	M2.5*6	T8	
VLT-22080D S25	22	176	255						
VLT-23080D S25	23	184	263						
VLT-24080D S25	24	192	271						
VLT-25080D S32	25	220	310	32	60	WCMX040208	M2.5*7D4	T8	
VLT-26080D S32	26								
VLT-27080D S32	27								
VLT-28080D S32	28								
VLT-29080D S32	29								
VLT-30080D S32	30								
VLT-31080D S32	31	260	350	32	60	WCMX050308	M3.0*8	T10	
VLT-32080D S32	32								
VLT-33080D S32	33								
VLT-34080D S32	34								
VLT-35080D S32	35	300	390	32	60	WCMX050308	M3.0*8	T10	
VLT-36080D S32	36								
VLT-37080D S32	37								
VLT-38080D S32	38								
VLT-39080D S32	39								
VLT-40080D S32	40								

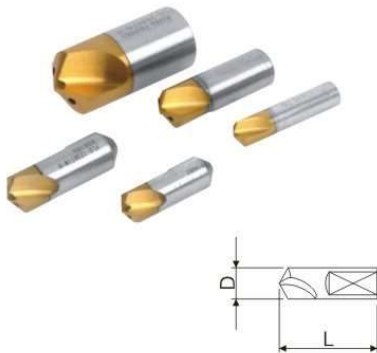

规格型号 Specification and model	D	L	适用钻头类型 Applicable drill bit type
PLD-V0630 TiN	6	30	VLT, TSD, TMD
PLD-V0835 TiN	8	35	VLT, TSD, TMD
PLD-V1035 TiN-H	10	35	VMD, VLT, MXD, TSD, TMD
PLD-V1238 TiN-H	12	38	VMD, VLT, MXD, TSD, TMD
PLD-V1645 TiN-H	16	45	VMD, VLT, MXD, TSD, TMD
PLD-2045 TiN-H	20	45	VMD, MXD
PLD-2556 TiN-H	25	56	VMD, MXD
PLD-3068 TiN-H	30	68	VMD, MXD

